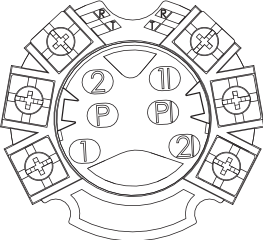
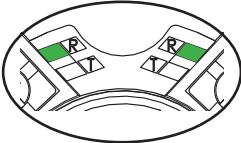
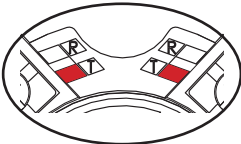
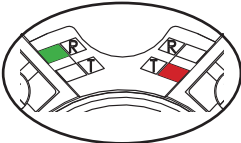

KSU2

Caractéristiques générales / General specifications

Modes de fonctionnement / Operation modes	<i>Maintenu / Impulsionnel / Mixte Sustained / Momentary / Combined</i>
Pouvoir de coupure / Switching capacity	240V AC / 5A
Contact (NO/C/NC)	2 inverseurs / 2 changeover
Indice de Protection / IP rating	54
Section des conducteurs / Conductor's cross-section	max. 2,5 mm ²
Température de fonctionnement / Operating temperature	- 30° + 50° C
Poids / Weight	0,28 kg

MODES DE FONCTIONNEMENT - MODES OF OPERATION

	<p><i>2x Maintenu 2x Sustained</i></p>	
	<p><i>2x Impulsionnel 2x Momentary</i></p>	
	<p><i>Mixte Combined</i></p>	

Agir sur les cavaliers vert (mode maintenu) et rouge (mode impulsionnel) pour modifier le mode de fonctionnement.
Le mode mixte permet d'avoir un mode de fonctionnement différent sur chaque contact inverseur.

*Act on the green (sustained mode) and red (momentary mode) jumpers to change the operating mode.
The mixed mode allows a different operating mode on each changeover contact.*

MONTAGE - MOUNTING

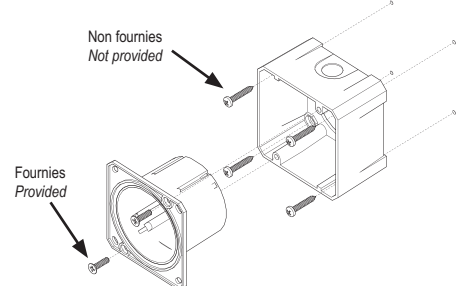
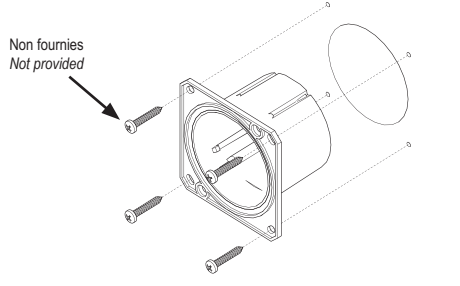
Montage en applique / Surface mounting	Montage encastré / Mortise mounting
 <p>Non fournies Not provided</p> <p>Fournies Provided</p>	 <p>Non fournies Not provided</p>

PROCÉDURE DE MONTAGE - ASSEMBLY PROCEDURE

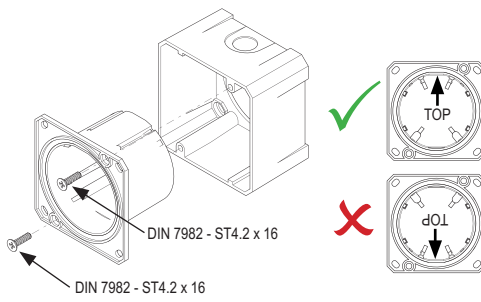
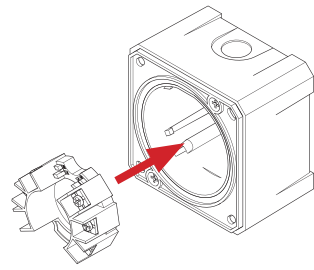
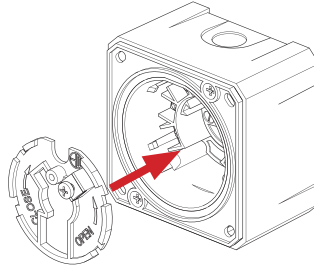
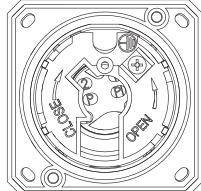
1	2
 <p>DIN 7982 - ST4.2 x 16</p> <p>DIN 7982 - ST4.2 x 16</p> <p>TOP</p> <p>dOL</p>	
<p>Seulement pour montage en applique Only for surface mounting</p>	<p>Mettre en place le contact électrique Set up the electrical contact</p>
3	4
	
<p>Mettre en place la plaque de verrouillage Install the locking plate</p>	<p>Tourner la plaque de verrouillage dans le sens CLOSE Turn the locking plate in the CLOSE direction</p>

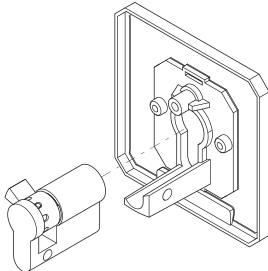
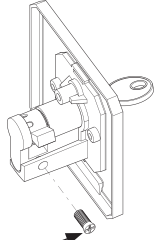
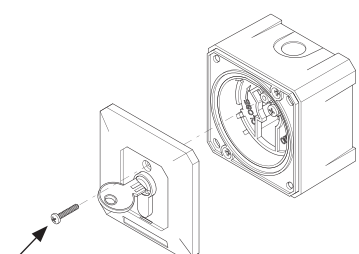
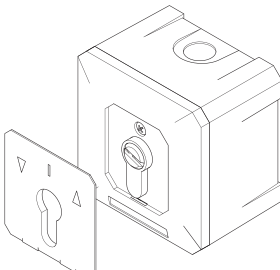
5	6
	 <p data-bbox="694 367 873 391">ISO 7046 - M5 x 19</p>
<p data-bbox="89 430 515 486">Mettre en place le demi-cylindre européen (non fourni) Insert the European half-cylinder (not supplied)</p>	<p data-bbox="672 430 963 486">Mettre en place la vis de verrouillage Insert the locking screw</p>
7	8
 <p data-bbox="100 837 235 861">DIN 7049 - ST3.5 x 19</p>	
<p data-bbox="67 901 548 1005">Tourner la clé de 45° (sens anti-horaire) à partir de la position verticale et insérer la serrure dans la plaque de verrouillage Turn the key 45° (counterclockwise) from the upright position and insert the lock into the locking plate</p>	<p data-bbox="716 925 918 981">Mettre en place le cache Replace the cover</p>

DIMENSIONS

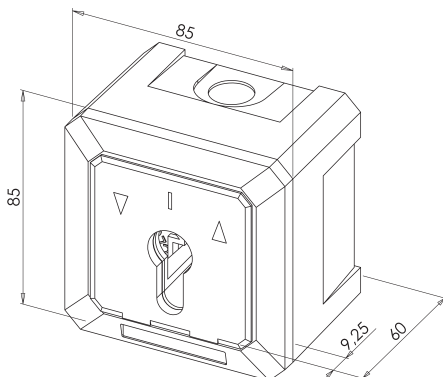

Raccordement d'un rideau métallique motorisé
 Connecting a motorised metal curtain

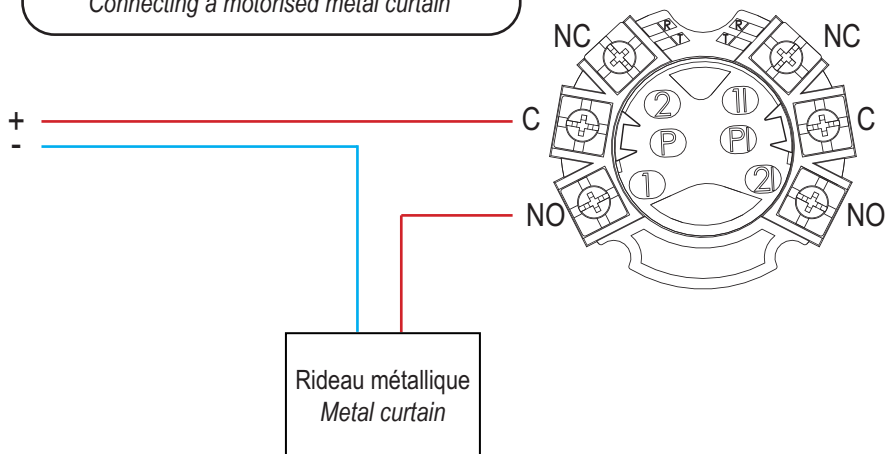

Raccordement du conducteur de protection sur la
 plaque de verrouillage
 Connecting the protective earth conductor to the
 locking plate

